

**one**

**Cambridge Audio**

Your music + our passion

**Make sure you register your purchase.**

Visit: [www.cambridge-audio.com/sts](http://www.cambridge-audio.com/sts)

**By registering, you'll be the first to know about:**

- **Future product releases**
- **Software upgrades**
- **News, events and exclusive offers plus competitions!**

This guide is designed to make installing and using this product as easy as possible. Information in this document has been carefully checked for accuracy at the time of printing; however, Cambridge Audio's policy is one of continuous improvement, therefore design and specifications are subject to change without prior notice.

This document contains proprietary information protected by copyright. All rights are reserved. No part of this manual may be reproduced by any mechanical, electronic or other means, in any form, without prior written permission of the manufacturer. All trademarks and registered trademarks are the property of their respective owners.

© Copyright Cambridge Audio Ltd 2014.

Cambridge Audio and the Cambridge Audio logo are trademarks of Cambridge Audio.

## Contents

Important safety instructions .....	3
Limited warranty.....	4
Rear panel connections.....	5
Front panel controls .....	6
Remote control .....	7
Connections.....	8
Operating instructions .....	10
Loading and playing CDs .....	10
DAB/FM Tuner .....	10
Bluetooth .....	11
Setting the clock .....	11
Setting the alarm time .....	11
Setting the sleep time.....	11
Tone control .....	11
Auto standby.....	11
Resetting the unit.....	11
Troubleshooting.....	12
Technical specifications.....	12

## Important safety instructions

For your own safety please read the following important safety instructions carefully before attempting to connect this unit to the mains power supply. They will also enable you to get the best performance from and prolong the life of the unit:

1. Read these instructions.
2. Keep these instructions.
3. Heed all warnings.
4. Follow all instructions.
5. Do not use this apparatus near water.
6. Clean only with a dry cloth.
7. Do not block any ventilation openings. Install in accordance with the manufacturer's instructions.
8. Do not install near any heat sources such as radiators, heat registers, stoves, or other apparatus (including amplifiers) that produce heat.
9. Do not defeat the safety purpose of the polarized or grounding-type plug. A polarized plug has two blades with one wider than the other. A grounding-type plug has two blades and a third grounding prong. The wide blade or the third prong are provided for your safety. If the provided plug does not fit into your outlet, consult an electrician for replacement of the obsolete outlet.
10. Protect the power cord from being walked on or pinched, particularly at plugs, convenience receptacles and the point where they exit from the apparatus.
11. Only use attachments/accessories specified by the manufacturer.
12. Use with only the cart, stand, tripod, bracket, or table specified by the manufacturer, or sold with the apparatus. When a cart is used, use caution when moving the cart/ apparatus combination to avoid injury from tip-over. 
13. Unplug this apparatus during lightning storms or when unused for long periods of time.
14. Refer all servicing to qualified service personnel. Servicing is required when the apparatus has been damaged in any way, such as the power-supply cord or plug having been damaged, liquid has been spilled or objects have fallen into the apparatus, the apparatus has been exposed to rain or moisture, does not operate normally, or has been dropped.

### WARNING

- To reduce the risk of fire or electric shock, do not expose this unit to rain or moisture.
- Batteries (battery pack or batteries installed) shall not be exposed to excessive heat such as sunshine, fire or the like.

The unit is of Class 1 construction and must be connected to a mains socket outlet with a protective earthing connection.

The unit must be installed in a manner that makes disconnection of the mains plug from the mains socket outlet (or appliance connector from the rear of the unit) possible. Where the mains plug is used as the disconnect device, the disconnect device shall remain readily operable.

Only use the mains cord supplied with this unit. Please ensure there is ample ventilation. We recommend that you do not place the unit in an enclosed space; if you wish to place the unit on a shelf, use the top shelf to allow maximum ventilation. Do not put any objects on top of this unit. Do not situate it on a rug or other soft surface and do not obstruct any air inlets or outlet grilles. Do not cover the ventilation grilles with items such as newspapers, tablecloths, curtains, etc.

This unit must not be used near water or exposed to dripping or splashing water or other liquids. No objects filled with liquid, such as vases, shall be placed on the unit.



The lightning flash with the arrowhead symbol within an equilateral triangle is intended to alert the user to the presence of un-insulated 'dangerous voltage' within the product's enclosure that may be of sufficient magnitude to constitute a risk of electric shock to persons.

The exclamation point within an equilateral triangle is intended to alert the user to the presence of important operating and maintenance instructions in the service literature relevant to this appliance.

### WEEE symbol



The crossed-out wheeled bin is the European Union symbol for indicating separate collection for electrical and electronic equipment. This product contains electrical and electronic equipment which should be reused, recycled or recovered and should not be disposed of with unsorted regular waste. Please return the unit or contact the authorised dealer from whom you purchased this product for more information.

### CE mark

This product complies with European Low Voltage (2006/95/EC), Electromagnetic Compatibility (2004/108/EC) and Environmentally-friendly design of Energy-related Products (2009/125/EC) Directives when used and installed according to this instruction manual. For continued compliance only Cambridge Audio accessories should be used with this product and servicing must be referred to qualified service personnel.

### C-Tick mark

This product meets the Australian Communications Authority's Radio communications and EMC requirements.

### EAC CU-TR Mark

This product meets Russia, Byelorussia and Kazakhstan electronic safety approvals.

## Important safety instructions cont.

### Ventilation

**IMPORTANT** – The unit will become hot when in use. Do not stack multiple units on top of each other. Do not place in an enclosed area such as a bookcase or in a cabinet without sufficient ventilation.

Ensure that small objects do not fall through any ventilation grille. If this happens, switch off immediately, disconnect from the mains supply and contact your dealer for advice.

### Positioning

Choose the installation location carefully. Avoid placing it in direct sunlight or close to a source of heat. No naked flame sources, such as lighted candles, should be placed on the unit. Also avoid locations subject to vibration and excessive dust, cold or moisture. The unit can be used in a moderate climate.

This unit must be installed on a sturdy, level surface. Do not place in a sealed area such as a bookcase or in a cabinet. Do not place the unit on an unstable surface or shelf. The unit may fall, causing serious injury to a child or adult as well as serious damage to the product. Do not place other equipment on top of the unit.

Due to stray magnetic fields, turntables or CRT TVs should not be located nearby due to possible interference.

Electronic audio components have a running in period of around a week (if used several hours per day). This will allow the new components to settle down and the sonic properties will improve over this time.

### Power sources

The unit should be operated only from the type of power source indicated on the marking label. If you are not sure of the type of power-supply to your home, consult your product dealer or local power company.

This unit can be left in Standby mode when not in use and will draw 1W in this state. To turn the unit off, unplug it from the mains socket.

### Overloading

Do not overload wall outlets or extension cords as this can result in a risk of fire or electric shock. Overloaded AC outlets, extension cords, frayed power cords, damaged or cracked wire insulation and broken plugs are dangerous. They may result in a shock or fire hazard.

Be sure to insert each power cord securely. To prevent hum and noise, do not bundle the interconnect leads with the power cord or speaker leads.

### Cleaning

To clean the unit, wipe its case with a dry, lint-free cloth. Do not use any cleaning fluids containing alcohol, ammonia or abrasives. Do not spray an aerosol at or near the unit.

### Battery disposal

Batteries may contain substances harmful to the environment. Please dispose of any discharged batteries with due consideration and in accordance with local environmental/electronic recycling guidelines.

### Servicing

These units are not user serviceable. Never attempt to repair, disassemble or reconstruct the unit if there seems to be a problem. A serious electric shock could result if this precautionary measure is ignored. In the event of a problem or failure, please contact your dealer.

## Limited warranty

Cambridge Audio warrants this product to be free from defects in materials and workmanship (subject to the terms set forth below). Cambridge Audio will repair or replace (at Cambridge Audio's option) this product or any defective parts in this product. Warranty periods may vary from country to country. If in doubt consult your dealer and ensure that you retain proof of purchase.

To obtain warranty service, please contact the Cambridge Audio authorised dealer from which you purchased this product. If your dealer is not equipped to perform the repair of your Cambridge Audio product, it can be returned by your dealer to Cambridge Audio or an authorised Cambridge Audio service agent. You will need to ship this product in either its original packaging or packaging affording an equal degree of protection.

Proof of purchase in the form of a bill of sale or receipted invoice, which is evidence that this product is within the warranty period, must be presented to obtain warranty service.

This Warranty is invalid if (a) the factory-applied serial number has been altered or removed from this product or (b) this product was not purchased from a Cambridge Audio authorised dealer. You may call Cambridge Audio or your local country Cambridge Audio distributor to confirm that you have an unaltered serial number and/or you made a purchase from a Cambridge Audio authorised dealer.

This Warranty does not cover cosmetic damage or damage due to acts of God, accident, misuse, abuse, negligence, commercial use, or modification of, or to any part of, the product. This Warranty does not cover damage due to improper operation, maintenance or installation, or attempted repair by anyone other than Cambridge Audio or a Cambridge Audio dealer, or authorised service agent which is authorised to do Cambridge Audio warranty work. Any unauthorised repairs will void this Warranty. This Warranty does not cover products sold AS IS or WITH ALL FAULTS.

REPAIRS OR REPLACEMENTS AS PROVIDED UNDER THIS WARRANTY ARE THE EXCLUSIVE REMEDY OF THE CONSUMER. CAMBRIDGE AUDIO SHALL NOT BE LIABLE FOR ANY INCIDENTAL OR CONSEQUENTIAL DAMAGES FOR BREACH OF ANY EXPRESS OR IMPLIED WARRANTY IN THIS PRODUCT. EXCEPT TO THE EXTENT PROHIBITED BY LAW, THIS WARRANTY IS EXCLUSIVE AND IN LIEU OF ALL OTHER EXPRESS AND IMPLIED WARRANTIES WHATSOEVER INCLUDING, BUT NOT LIMITED TO, THE WARRANTY OF MERCHANTABILITY AND FITNESS FOR A PRACTICAL PURPOSE.

Some countries and US states do not allow the exclusion or limitation of incidental or consequential damages or implied warranties so the above exclusions may not apply to you. This Warranty gives you specific legal rights, and you may have other statutory rights, which vary from state to state or country to country.

For any service, in or out of warranty, please contact your dealer.

### Plug Fitting Instructions (UK only)

The cord supplied with this appliance is factory-fitted with a UK mains plug fitted with a 5-amp fuse inside. If it is necessary to change the fuse, it is important that a 5-amp fuse is used. If the plug needs to be changed because it is not suitable for your socket, or becomes damaged, it should be cut off and an appropriate plug fitted following the wiring instructions below. The plug must then be disposed of safely, as insertion into a mains socket is likely to cause an electrical hazard. Should it be necessary to fit a 3-pin BS mains plug to the power cord, the wires should be fitted as shown in this diagram. The colours of the wires in the mains lead of this appliance may not correspond with the coloured markings identifying the terminals in your plug. Connect them as follows:

The wire which is coloured BLUE must be connected to the terminal which is marked with the letter 'N' or coloured BLACK.

The wire which is coloured BROWN must be connected to the terminal which is marked with the letter 'L' or coloured RED.

The wire which is coloured GREEN/YELLOW must be connected to the terminal which is marked with the letter 'E' or coloured GREEN.

If a standard 13-amp (BS 1363) plug is used, a 5-amp fuse must be fitted or, if any other type of plug is used, a 5-amp fuse must be fitted, either in the plug or adaptor, or on the distribution board.

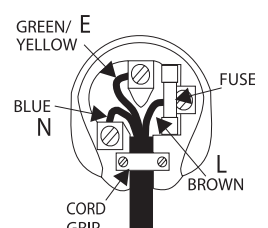

## Rear panel connections

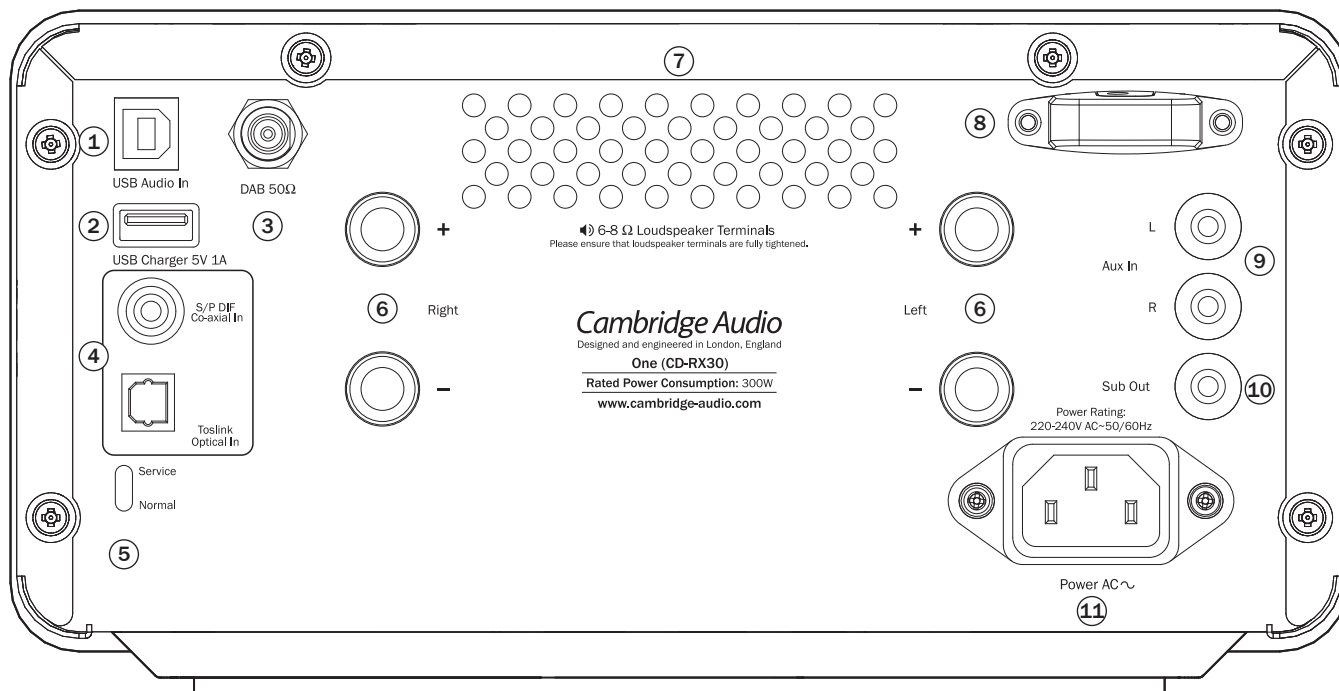

### 1 USB Interface

A USB B type socket is fitted to the One to enable the playback of audio from a personal computer running either Microsoft Windows or Apple Mac OS X operating systems. Some builds of Linux are also suitable.

**Note:** Always use a high quality USB connection cable certified as USB Hi-Speed. USB cable connections longer than 3m may result in inconsistent audio performance.



Always turn the Volume to minimum, switch to another input or turn the One off before plugging/unplugging cables to the USB input or whilst booting up/shutting down your PC/Mac.

### 2 USB charger

Use this USB socket to charge a portable device. 1A maximum current consumption.

### 3 DAB Aerial Input

The One has a 50Ω F-type screw connection aerial for DAB and FM signals. A temporary aerial is supplied in the box. Once connected, extend the aerial and move it around until the best reception is achieved.

For continued use, we strongly recommend using an outdoor aerial.

### 4 Digital inputs

**S/P DIF Co-axial** – Use a high quality 75 ohm digital RCA Phono interconnect cable (not one designed for normal audio use). This input is suitable for 16-24 bit content up to 192kHz.

**Toslink Optical** – Use a high quality TOSLINK fibre optic interconnect cable designed specifically for audio use. This input is suitable for 16-24 bit content up to 96kHz (Toslink is not recommended at 192kHz sampling rates).

**Note:** To obtain the best results from your system we recommend using only high quality Cambridge Audio interconnects. This will ensure that you hear your system as we designed it. Please ask your dealer for details.

### 5 Service/Normal

**For dealer use only** – Switches the One between normal (default) and service mode. Do not change the mode to service mode as damage may result!

### 6 Speaker terminals

These terminal connectors can be pulled out to allow connection of banana plugs.



Connect the wires from your left channel loudspeaker to the Left + & - terminals, and the wires from the right channel loudspeaker to the Right + & - terminals.

Care should be taken to ensure no stray strands of wire short the speaker outputs together. Please ensure that your speaker wires are properly inserted to provide a good electrical connection. It is possible for the sound quality to be affected if the connections are loose.

### 7 Heat tunnel vent grille

Allows cooling of internal circuitry via the One's proprietary X-TRACT heat tunnel. **DO NOT OBSTRUCT!**

### 8 Bluetooth

Used for wireless streaming bluetooth (A2DP/AVRCP) audio capability directly from most phones, tablets and laptops. See later section for details.

### 9 Aux input

This input is suitable for any 'line level' source equipment such as the audio outputs of a DVD player, Satellite/Cable receiver etc.

### 10 Sub out

For optional connection to a powered subwoofer.

### 11 AC power socket

Once you have completed all connections to the unit, plug the AC power cable into an appropriate mains socket then switch on. Your One is now ready for use.

## Front panel controls

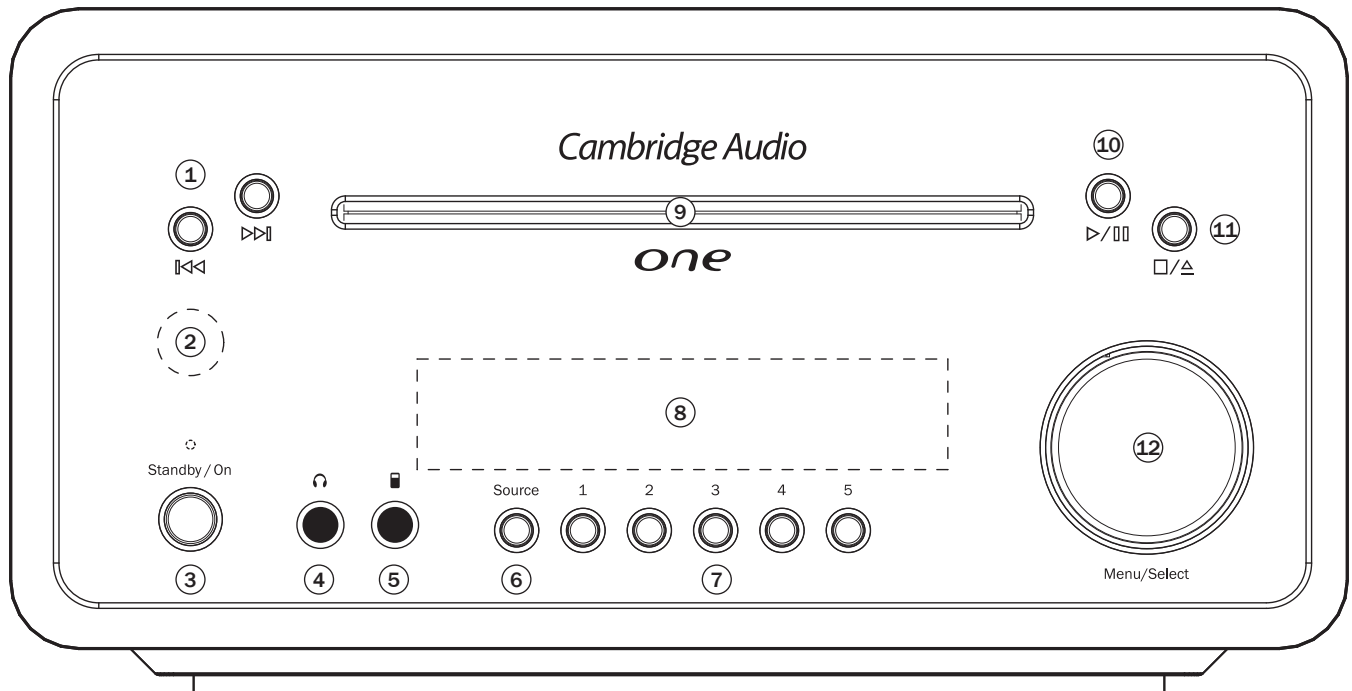

### ① Skip/Scan

Use for skipping between tracks during playback. These buttons are also used to scroll through available stations in DAB/FM mode. For more information refer to 'Operating instructions'.

### ② Infrared sensor

Receives IR commands from the supplied remote control. A clear unobstructed line of sight between the remote control and the sensor is required.

### ③ Standby/On

Switches the unit between Standby mode (indicated by the time on the display) and on. Standby is an eco-friendly <1W low power mode. The unit may be left in Standby mode when not in use.

This product has Auto Standby enabled as default. After inactivity of 30 minutes, the product will automatically switch to Standby. See later section for further details.

### ④ Phones

Allows for the connection of stereo headphones with a 3.5mm jack plug. Headphones with an impedance of between 32 and 600 ohms are recommended.

**Note:** Plugging in headphones will automatically mute the loudspeaker output.

### ⑤ (MP3) input

This source input allows you to connect a portable audio device such as an MP3 player directly into the front of the unit using the 3.5mm stereo-jack (labelled 'MP3'). Select the MP3 input source through the main menu 'Audio Inputs' or direct MP3 button on the remote to listen to your portable audio device.

### ⑥ Source

Pressing this button will cycle through different sources: CD, DAB, FM, Aux, Bluetooth, USB Audio, Opt and Coax inputs. Press the Select control knob to select the source.

### ⑦ Presets

The One can store up to 5 presets for each of the DAB and FM bands. All 5 per band are available from the remote control and also from the front panel.

Press and hold the appropriate button to store the presets. Press the appropriate button to access the stored presets. See later sections for more information.

### ⑧ Display

LCD used to display playback, sources, settings etc. Refer to 'Operating instructions' for more information.

### ⑨ CD Disc slot

Supports Audio CD's (CD-DA), MP3 files and WMA files played from CD, CD-R or CD-RW discs. Disc can be inserted into the unit in any mode but not in Standby mode.

### ⑩ Play/Pause

Plays and pauses playback.

### ⑪ Stop/Eject

Press during playback to stop and press again to eject the Disc.

### ⑫ Volume control/Menu navigation and select

Rotate to adjust the volume.

Press and hold will switch to menu navigation. In menu navigation rotate the control to move between various items and press the control in to select the highlighted item. Press and hold again to exit menu settings.

## Remote control

The One is supplied with a remote control handset that duplicates the front panel control and functions. The supplied AAA batteries must be fitted before the remote control can be used.

### 1. Mute

Press to mute/unmute the speaker outputs.

### 2. Standby/On

Switches the One between On and low power eco-friendly Standby mode.

### 3. Numerics

**Tuner mode** – Allows access to stored preset stations. Press the numeric 1–5 button.

**CD mode** – Enable direct CD track selection. Press the number of the desired track to begin playback from the beginning. To select a track number greater than 9, press the -/-- button followed by the track number.

### 4. Prog. 5. Random and 6. Repeat

Press to select various playback modes. Refer to the 'Operating instructions' section of this manual for information on the functions of these buttons.

### 7. Volume Up/Down

Volume adjustment.

### 8. Scan

Press and hold to scan within the selected track. Hold down for a few seconds to increase scan speed. Press the right button to fast forward, the left button to rewind.

### 9. Play/Pause

Press to play/pause CD playback.

### 10. Skip

Use for skipping between tracks during CD playback or to scroll through available station in DAB/FM mode.

### 11. Stop/Eject

Press to stop CD playback. Press again to eject the Disc.

### 12. Source buttons

The 8 source select buttons are used to directly select the input source.

### 13. Return

Press to return to the previous menu.

### 14. Menu

Press to access the main menu.

### 15. Info

Press to select and view different information on the front panel display. The display modes are as follows:

Tuner mode – Radio Text, Transmission group, Time/Date, Signal quality, Program type.

### 16. Sleep

Press to enable and set the sleep function. This will turn the unit off after a selected interval.

### 17. Brightness display

Alters the brightness of the display's backlights. There are two brightness levels and an option to switch off the backlight.

When the display is set to Off, nothing will be displayed onscreen until a selection is made via the front panel or remote control. The display will then re-activate allowing you to browse the menu and make your selection. The display will then automatically switch back off after a few seconds if no further selections are made.

### 18. Alarm

Press to enable and set the alarm function. See later section for further details

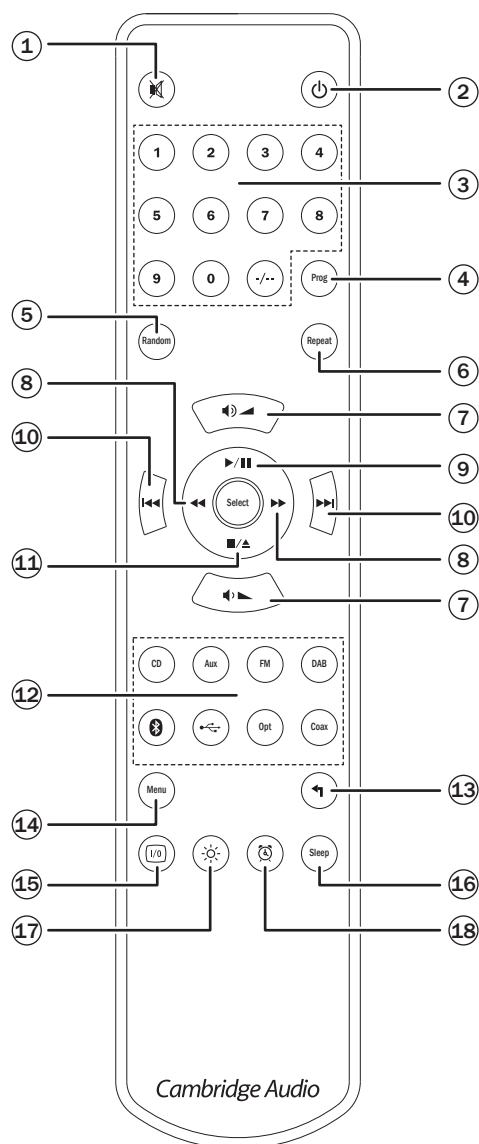

## Connections

### Speaker connections

Check the impedance of your speakers. Speakers with an impedance of between 6 and 8 Ohms are recommended.

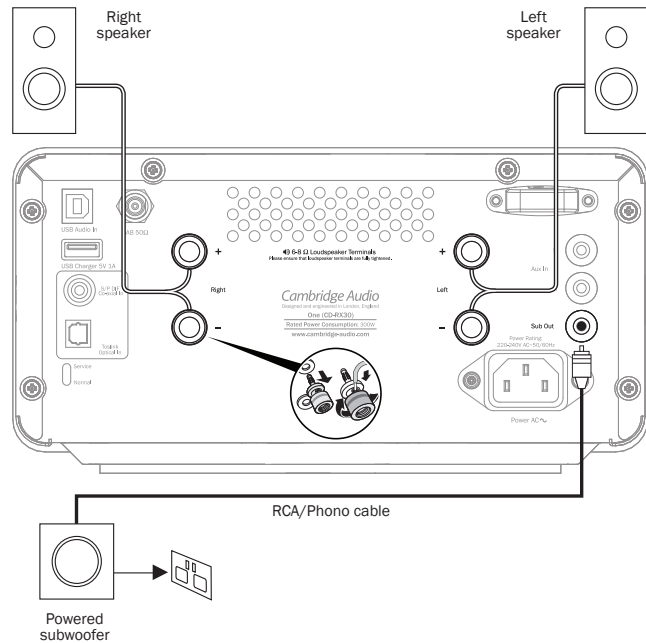

The red coloured speaker terminals are positive (+) and the black speaker terminals are negative (-). Make sure correct polarity is maintained at each speaker connector or the sound can become weak and "phasey" with little bass.

Prepare the speaker cables for connection by stripping off approximately 10mm (3/8") or less of the outer insulation. More than 10mm could cause a short circuit. Twist the wires tightly together so there are no loose ends. Unscrew the top of the speaker connection plugs in the back of the unit loose enough to feed the bare ends of cable through. Feed the cable through the hole then tighten the connection so the bare cable is tightly clamped and there are no loose strands exposed.

**Note:** All connections are made using standard loudspeaker cable. If an active subwoofer is used, connect via a standard single RCA/phono cable (often referred to as a 'Sub-Link').

### Analogue audio connections

**Note:** Do not plug in the mains power lead or turn the unit on until all connections have been made.

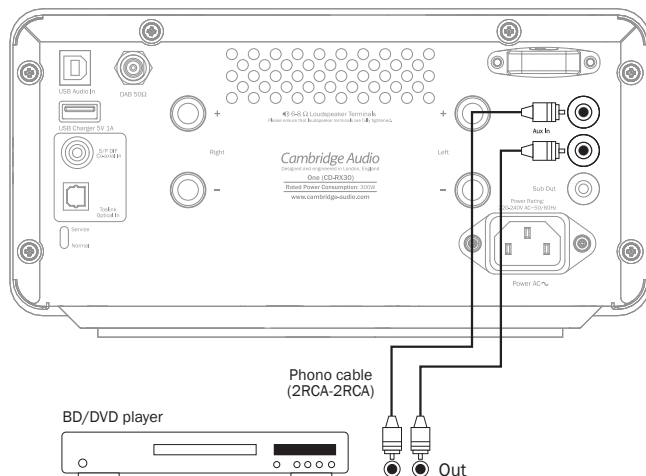

Connect to source equipment using stereo phono/RCA cables (stereo 2RCA-2RCA). Require two sets of stereo phono/RCA cables, one for recording, one for listening.

### Digital audio connection

There are two types of digital audio connections can be made to the unit:

1. S/P DIF Co-axial
2. Toslink

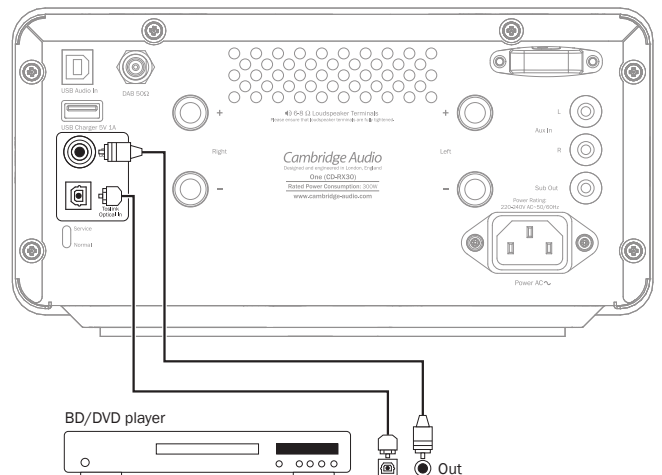

Both connections can be used at the same time as these are selectable as separate sources.

For S/PDIF connection, always use a 75ohm RCA/Phono to RCA/Phono lead designed specifically for digital audio.

The TOSlink connection requires a special TOSlink optical fibre lead. See your dealer for details.

### Bluetooth

The One has a built-in Bluetooth adaptor. This allows the One to receive wireless Bluetooth audio from most phones/tablets and laptops.

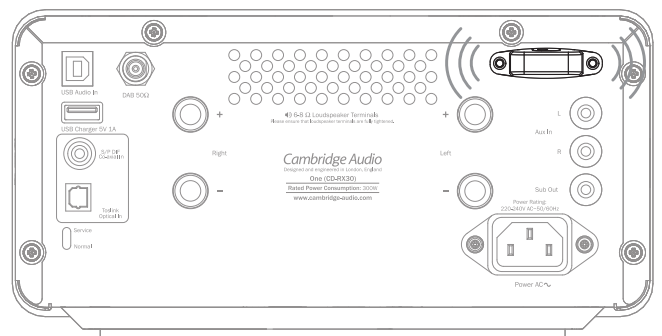



### DAB/FM aerial

The One has a 50 Ω F-type screw connection aerial for DAB and FM signal. Connect the supplied DAB/FM aerial to the socket.

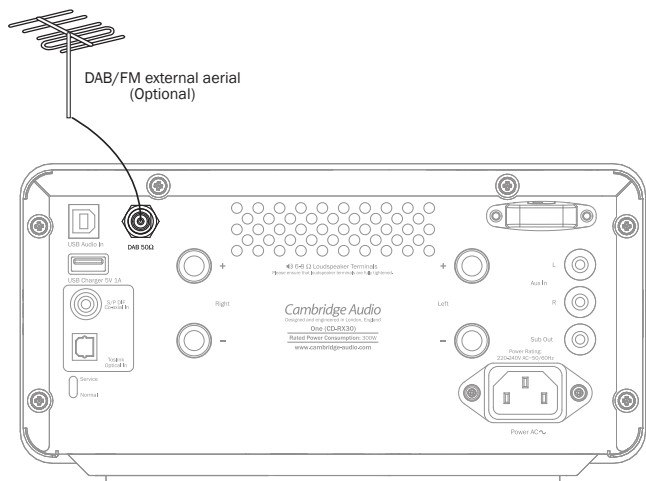

**Note:** The One is supplied with a temporary DAB/FM aerial for initial use only. For permanent use, outdoor aerials are highly recommended.

### USB audio

The One USB input enables the playback of audio files or streamed programme from Microsoft Windows or Apple Mac OS X personal computers (and some Linux builds). When connected via USB the personal computer will identify the One as an audio device. Specifying the One in the computer's audio control panel will enable it to play audio data either stored locally on the computer or streamed to the computer via a network or the internet. The One is a USB 1.1 (Full-speed) USB port compatible.

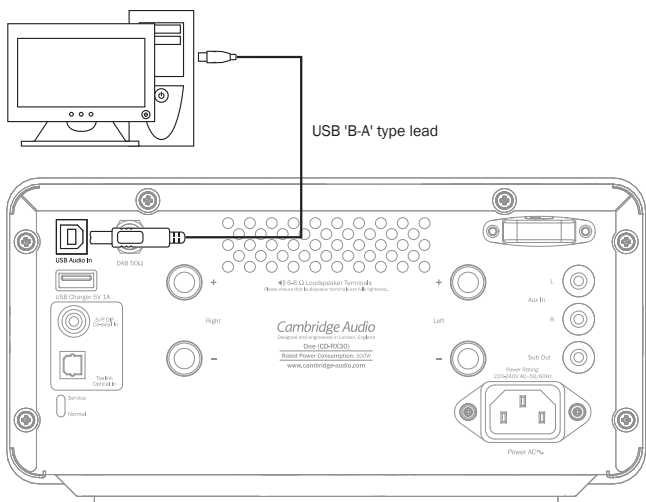

**Always turn the Volume to minimum, switch to another input or turn the One off before plugging/unplugging cables to the USB input or whilst booting up/shutting down your PC/Mac.**

**Note:** Always use a high quality USB connection cable certified as USB Hi-Speed. USB cable connections longer than 3m may result in inconsistent audio performance.

The One only supports USB 1.1 and USB Audio 1.0, which works with nearly all common operating systems and computer types without drivers and supports up to 24-bit/96kHz audio, simply plug in and play.

In this configuration the One is able to work at up to 24-bit/96kHz by declaring to your computer that it can handle any sample rate from 32kHz to 96kHz.

However in some Windows/Mac operating system variants the operating system itself may restrict or fix the output sample rate or re-sample the audio.

See our online guide at <http://support.cambridgeaudio.com> on USB Audio for more details on this. With careful choice of playback software and settings many pitfalls can be avoided.

A brief explanation of your choices are as follows:

#### Use with PCs

With the One using the USB Audio 1.0, the One will work with the native Windows XP, Vista, Windows 7 or 8 Audio 1.0 driver (no need to load any new driver) and accept audio up to 24-bit/96kHz.

#### Use with Macs

No extra drivers are required. With the One using the USB Audio 1.0, the One will work with the native Mac OS-X 10.5 (Leopard) or above Audio 1.0 driver and accept audio up to 24-bit/96kHz.

#### Use with Linux

For most distributions of Linux with the One using the USB Audio 1.0, the One will work with the native Audio 1.0 driver and accept audio up to 24-bit/96kHz.

For this case because Linux distributions vary according to their creators choice of software components including drivers it is not possible to guarantee operation and Audio drivers may need to be loaded.

'Class drivers' as they are called for generic support of Audio Class 1.0 devices may be available from the Linux community, we do not supply these.

## Operating instructions

Once all the required input and output connections are made, the One can be switched on using its rear panel Power switch and front panel or handset Standby/On button.

Either front panel or handset buttons can be used for the majority of the One control functions.

To use the One as a conventional CD player, proceed as described in the following paragraphs:

### Loading and playing CDs



This unit has been designed to play compact discs, recordable CDs (CD-R) and re-writable CDs (CD-RW) bearing the identification logo shown here. No other discs can be used. Any CD-R/CD-RW discs should contain properly recorded TOC (Table of Contents) information so that they can be played back. This unit can play only the discs recorded in the CD-DA format designed for music reproduction. Do not attempt to play a disc containing other data, such as a CD-ROM for PCs with MP3 or WMA files, on this unit.

#### Compatible bitrates

**MP3** – 96, 128, 192, 256 and 320 kbps.

**WMA** – 48, 64, 96, 128, 160 and 192 kbps.

1. Select CD mode or load the disc into the CD slot. Once the disc is loaded, the source will automatically switch to CD mode.
2. The disc will automatically start playing from the beginning of the first track. When the last track has finished playing, the unit will go to Standby mode.
3. To stop the disc at any point, press the *Stop* button. Pressing the *Pause* button while the disc is playing will pause the disc. When the disc is paused the display will flash, play can be resumed by pressing the *Pause* button again.
4. To eject disc, press the *Stop* button to stop the play back and press again to eject the disc.

#### IMPORTANT!:

- Do not put anything except a compatible disc into the disc slot. Foreign objects may damage the mechanism.
- If a disc is seriously scratched or dirty the player may not be able to read or play it.
- Never load more than one disc at a time into the disc slot.
- Once the disc is ejected from the disc slot, do not push the disc back inside while the disc is in the slot. To re-insert the disc, take the disc out of the slot and put back into the slot.

#### Playing a specific CD track

With the One switched on and a disc loaded, specific tracks can be selected for playback by pressing one of the front panel or handset **◀ ▶** buttons to step through the tracks on the disc forwards or backwards. When the desired track is shown on the One display, press the front panel or handset *Play* button to begin playback. The disc will then play from the selected track to the end.

**Note:** The numerical buttons on the remote can be used for playing specific track.

#### Scanning within tracks

With the One switched on and a disc playing, a specific point in a track can be found by pressing and holding one of the front panel or handset *Scan* buttons to fast-forward or fast-reverse through the track. When the desired point in the track is reached the button can be released. The disc will then play from the selected point to the end.

#### Repeating discs and tracks

With the One switched on and a disc playing, either a specific track or an entire disc can be set to repeat indefinitely. To repeat a specific track press the handset *Repeat* button once while the track is playing. The One display will show "Repeat Track". To repeat an entire disc simply press the handset *Repeat* button twice in quick succession. The One display will show "Repeat All". Track or disc repeat can be cancelled by a further press of the *Repeat* button, by pressing the front panel or handset *Stop* button or by opening the disc drawer.

#### Playing tracks randomly

With the One switched on and a disc loaded, the tracks can be played randomly. To select random play simply press the handset *Random* button once and then the *Play* button. Random play can be cancelled by a further press of the *Random* button. The disc will then continue to play the tracks in the "correct" order following the track that was playing when random play was cancelled.

#### Programming disc play

The order in which CD tracks are played can be programmed with a playlist. Tracks can also be suppressed from a playlist or programmed to play more than once.

With the One switched on and a disc loaded, press the handset *Prog* button. The One display will show the Program menu. Use the front panel or handset **◀ ▶** buttons to step through the disc to the track you wish to be the first track in the playlist. Press the *Select* button on the remote to confirm the first track. Repeat this procedure for all the tracks required in the playlist and then press the front panel or handset **■** button to store the programmed playlist. When the playlist is stored, use the front panel or handset **▶** button to play the programmed playlist.

The front panel or handset **||**, **◀ ▶** and **◀ ▶** functions can be used as normal while a programmed playlist is playing. Press the front panel or handset **■** button once to stop playback without deleting the playlist, or press it twice both to stop playback and delete the playlist.

### DAB/FM Tuner

Press the Standby/On button. Press either the FM or DAB source button.

#### FM mode

To tune and listen to stations, do the following:

1. Press the **◀** button to scan up to the next available station.
2. Press the **▶** button to scan to previous available station.

**Note:** For manual tuning, press and hold either of the **◀ ▶** buttons. This will step the frequency by 0.05MHz.

#### DAB mode

When selecting DAB mode for the very first time, the unit will initiate a 'Full Service Scan' for DAB services (can take up to 3 minutes to complete). A scanning bar appears on the display while scanning for stations. When scanning is completed, the unit will default to the DAB source mode. Use the **◀ ▶** buttons to cycle through receivable stations.

A partial or full scan for DAB station scan also be initiated at any time in the future (see later section).

Press Enter to tune to and listen to the selected station.

#### Note:

- When scrolling through stations, as default the unit will revert to the previous station if no station is selected or button pressed for 3-4 seconds. The One can also automatically tune to any displayed station after 3-4 seconds of inactivity if required. When in DAB mode press and hold the front panel or remote control **▶ / ||** control. After 4 seconds an "Auto Enter On" or "Auto Enter Off" message will be displayed. Press **▶ / ||** to repeatedly toggle between these two settings then either press no button for a few seconds or press in the *Volume/Select* control to exit and save the setting.
- The number of DAB stations received will depend on aerial signal strength. We recommend completing a full auto scan from time to time to pick up new DAB stations.
- In DAB mode you can also press the Menu button which will first bring up a <Station Select> menu item. This also allows you to scroll to and select any desired station using the volume control.

#### DAB settings

It is possible to change the DAB region setting for this unit. This is necessary if the unit has been moved to a different region location.

**Note:** Changing the DAB region will erase all the stored DAB presets.

1. Press the *Menu* button on the remote to go to the menu settings.
2. Use the **◀ ▶** buttons and select 'Tuner Setup > Tuner Region'. Press the *Select* button to change the tuner region settings.
3. Use the **◀ ▶** buttons to browse through the available country DAB region setting Europe, Korea, USA, Australia, Canada, China and Taiwan.
4. Select the correct region and press the *Select* button to accept the new changes.
5. Restart the unit and perform a full station scan.

## Setting presets

To store a station as a preset do the following:

1. Press and hold the desired *Preset* button on the remote or front of the unit.

## How to select preset stations

1. Select FM or DAB mode by pressing the corresponding button on the remote.
2. Press the corresponding *Preset* button on the remote or front of the unit to access Presets 1-5.

## Resetting the presets

This will erase all stored presets for DAB and FM. It will also cause the unit to perform a full scan for DAB stations when the unit is turned on.

1. Press the *Menu* button on the remote to access the menu settings.
2. Use the ◀ ▶ buttons to navigate and select 'Factory Reset'. Press the *Select* button to accept the confirmation and erase all presets.
3. Restart the unit.

**Note:** Performing a factory reset will erase all stored presets and other stored settings.

## Bluetooth

When bluetooth devices are paired to your One, it allows the One to receive bluetooth audio (known as Bluetooth Advanced Audio Distribution Profile or A2DP).

The One supports Bluetooth A2DP using the original SBC encoded form.

SBC refer to the encoding used over the wireless Bluetooth interface only and not the format your music may be in, which can be any type that your phone/ laptop or other playing device supports.

Your playing device plays your files then re-encodes the playback before streaming it to the One.

Many phones and laptops now feature Bluetooth with A2DP. SBC should be supported by all such devices (it is the mandatory format for A2DP).

## Pairing

To begin streaming high quality music from your chosen media source it will first need to be paired with the One.

Select the Bluetooth source via the remote or using the *Source* button on the front panel.

Put your Bluetooth compliant audio source into pairing mode. Please consult your manufacturer's user manual on how to do this.

Pairing your One and source establishes an authorised audio link that can then be used again in the future without having to go through this stage again.

After pairing you can just select the Bluetooth from the menu and play at any time as long as your Bluetooth A2DP compatible source (phone/laptop etc.) is within approx. 10m of the One.

Normally on your source you will need to select Bluetooth Pairing and then the One should appear as 'Cambridge Audio One' in a list of locally found Bluetooth devices.

Select that item in the list to finish pairing.

On successful pairing, the display on the front will show 'Paired'.

To play back via a paired Bluetooth device, simply select the One on that device and start playing.

## Setting the clock

The user can either allow RDS transmissions to automatically set the clock Time/ Date, or the clock can be set manually. To change the clock mode:

1. Press the *Menu* button on the remote to access the menu settings.
2. Use the ◀ ▶ buttons on the remote to navigate and select 'Clock Setup > Set Time'.
3. Adjust the hour using the ◀ ▶ buttons on the remote.
4. Press the *Select* button to adjust the minutes.
5. Adjust the minutes using the ◀ ▶ buttons on the remote.
6. Press the *Select* button to accept the settings and exit.

## Setting the alarm time

### Setting the Alarm with the remote

1. Press the *Alarm* button.
2. Select 'On' or 'Off' – selecting off will take the unit back out of the menu, selecting 'On' will allow the alarm time to be set.
3. Adjust the hour using the ◀ ▶ buttons.
4. Press the *Select* button to adjust the minutes.
5. Adjust the minutes using the ◀ ▶ buttons.
6. Press the *Select* button to accept the settings and exit.

### Setting the Alarm on the unit

1. Enter the menu by holding down the 'Select' knob.
2. Using the scroll wheel select the 'Alarm Setup' menu page.
3. Select the menu items using the 'Select' knob.
4. Once the setting is chosen using the 'Select' knob the menu will step back to the 'Alarm Setup' menu page.

The 'Alarm On/Off' menu allows the user to enable or disable the alarm function.

The 'Alarm Time' menu allows the user to set the alarm activation time.

The 'Alarm Source' allows the user to choose which source is used as the alarm.

The 'Alarm Volume' allows the user to select the volume at which the alarm sounds.

## Setting the sleep time

The Sleep function will turn off the One at a chosen time interval.

To set the Sleep time:

1. Press the *Sleep* button on the remote.
2. By pressing the *Sleep* button on the remote, the Sleep function will cycle through the menu: Sleep Off, Sleep 10, 20, 30, 40, 50, 60, 70, 80 and 90 minutes.
3. Press the *Select* button to finish and exit the menu.

## Tone control

These controls allow subtle adjustments to the tonal balance of the sound. Modify the sound through your loudspeakers. With a well produced CD the tone controls are unnecessary and can be bypassed by selecting the *Direct* function.

1. Press the *Menu* button on the remote.
2. Use the ◀ ▶ buttons to browse through the menu: *Direct*, *Balance*, *Bass* and *Treble*.
3. Press the *Select* button to select the desired tonal adjustments.
4. Use the ◀ ▶ buttons to change mode.
5. Press the *Select* button again to finish and exit the menu.

**Note:** When the tone control *Direct* is set to "On", other tonal adjustment is not possible. Turn this function off to enable other tonal adjustments.

## Auto standby

This product has Auto Standby enabled as default. After inactivity of 30 minutes, the product will automatically switch to Standby. To disable/enable this function, go to the Menu setting and navigate to "Auto Standby" and selecting "On/Off".

## Resetting the unit

A full reset of unit can be performed by going to the Menu setting and navigate to "Factory Reset". To proceed with the factory reset, select "Yes".

**Note:** Performing a factory reset will erase all stored presets and other stored settings.

## Troubleshooting

### There is no power

- Ensure the AC power cord is connected securely.
- Ensure the plug is fully inserted into the wall socket and is switched on.
- Check fuse in the mains plug or adaptor.
- Check the unit is switched on via the back panel.

### The player will not read the disc

- Check the disc is not loaded upside down.
- Check that the disc is not too scratched or dirty.
- Check the disc type is suitable.

### There is no sound

- Ensure that the volume is set at an audible level.
- Check that the speakers are connected correctly.
- Check aerial connections and an available station is selected.
- Check that the right source is selected.
- Check the unit is not in mute.

### The disc is skipping

- Check that the disc is not too scratched or dirty.
- Ensure the player is on a firm surface and not subject to vibrations.

### The sound is distorted

- Check aerial connections and placements.
- Check the speaker connections.

### The remote handset will not function

- Check the polarity and that the batteries have not expired.
- Ensure that nothing is blocking the remote sensor.
- Perform a System Reset.

### The unit does not pick up enough DAB stations

- Check the aerial has strong signal.
- Re-orientate the aerial.
- Perform a System Reset.

### The display on the unit is distorted

- Perform a System Reset.

### There is a hum coming from the speaker

- Ensure that all cable connections are secure, particularly ground/shield connections.

### There is unwanted background noise and interference

- Move the unit away from other electrical equipment that is likely to cause interference.
- Re-orientate the aerial.

In the event that the above solutions do not remedy your problem, please consult our frequently asked questions (FAQ) section on our website: [www.cambridge-audio.com/sts/faqs](http://www.cambridge-audio.com/sts/faqs)

You can also use this facility to post a question to our Technical Support team. For all servicing, in or out of warranty, please contact your dealer.

## Technical specifications

D/A Converter	Wolfson WM8728 24-bit/96kHz DAC
Power output	30 watts rms (into 8 Ohms) 40 watts rms (into 6 Ohms)
Frequency response (+0.5dB)	5Hz - 50kHz
S/N ratio (A weighted)	>92dB relative to max output
Input impedances	47kohms
THD+N (unweighted)	<0.02% @ 1kHz <0.09% @ 20kHz
Tone control	
Bass	± 12dB @ 100Hz
Treble	± 10dB @ 10kHz
Aerial input	50 Ω FM/DAB
DAB bands	III/L
FM bands	87.5 - 108 MHz
CD	CD-DA/MP3/WMA/LPCM CD playback is intrinsically limited to 16-bit 44.1kHz
Digital inputs	S/PDIF Co-axial and TosLink Optical PCM 16-24-bit, 32-96kHz
USB audio input	USB Type B conforming to Audio profile 1.0.
Compatibility	USB 1.0: 24-bit 32kHz, 44.1kHz, 48kHz, 96kHz Toslink: 16/24-bit 32-96kHz S/PDIF: 16/24-bit 32-96kHz Bluetooth: SBC
Other connections	1 x 3.5mm headphone output (32 To 600 ohms recommended) 1 x Sub Out 1 x IEC type mains inlet
USB charger current rating	5V 1A.
Standby power consumption	1W
Rated power consumption	300W
Dimensions	230 x 112 x 295mm (9.0 x 4.4 x 11.6")
Weight	5.8kg (12.8lbs)

Cambridge Audio is a brand of Audio Partnership Plc  
Registered Office: Gallery Court, Hankey Place  
London SE1 4BB, United Kingdom  
Registered in England No. 2953313

[www.cambridge-audio.com](http://www.cambridge-audio.com)

